



MISAMIS UNIVERSITY

OZAMIZ CITY

College of Engineering and Technology



Lighting and Power Control with Monitoring System using Quick Response

(QR) Code with NODEMCU Micro-controller

Presented to Electrical Engineering Department

Misamis University

Ozamiz City

In Partial Fulfillment of the Subject EE 415C

Submitted to

Engr. Isidro M. Dalis JR.

Submitted by

VIT MCDOWELL P. SARIGUMBA

JUDE ANDREW G. TAGA-AN

FAITH R. GARCIA

TABLE OF CONTENTS

Acknowledgement	1
Abstract	2
Introduction	3
Purpose of the Study	4
Block Diagram	4
Working Principle	5
Scope of the study	6
Definition of terms	6
Methodology	8
Results and discussions	26
Conclusion	29
Recommendations	29
Literatures cited	31
Appendices	33
Curriculum Vitae	55

ACKNOWLEDGEMENT

The researchers would like to convey their gratitude and appreciation to Misamis University's College of Engineering and Technology for providing us with the proper training ground, skills, and values that aided us in conducting the research. We would also like to thank the people listed below for their unwavering support, help, and contributions in this sector.

To our research teacher Engr. Isidro M. Dalis Jr. for his patience in teaching us the right format and material, providing us with the information and understanding we required to accomplish this critical prerequisite.

To the researchers who acted as the study's cornerstones. That this study was carried out as a result of the expertise and ideas they shared. Their devotion, patience, and hard work made a significant contribution to this research.

To the researchers' parents, who understood and supported us financially, morally, and emotionally during this research endeavor.

Finally, we thank our Almighty Father, the source of light and knowledge, for giving us the strength and direction we needed to complete this study, as well as for directing and maintaining the researchers' unshakeable spirit throughout the process

ABSTRACT

Lighting and Power Control with Monitoring System using Quick Response (QR) Code with NODEMCU Micro-controller is a project that operates through the nodemcu and QR code with the help of IOT. Modern power control systems use a variety of techniques, and it has been shown to significantly reduce energy costs. However, the technology required to put such a system in place is prohibitively costly. As an alternative, the researchers strive to implement and use nodecmu. Not only does it reduce operating costs, but it also cuts installation costs. Researchers have focused on managing the electricity system within the school or classroom for this project. In order to make power operate well and be simple to use, these devices have come to be the focus of many projects in the building automation industry. The automation system for schools and classrooms in this project idea has improved energy management and greater power quality. The power control system for this project makes use of a straightforward relay circuit, which is monitored by IOT and controlled by a nodecmu. Two loads are connected using nodemcu in the design and may be managed and monitored through a QR code or the Internet of Things. The user must register on the website in order to obtain a QR code. Once registered, the user may control the power using the registered QR code. The nodemcu delivers information to the website logs for the monitoring system after scanning the QR code. Through the website, the user may also change the power. On the hardware side, activities will be carried out by the QR code scanner and relay, whilst the nodemcu is the primary component that processes all actions using MySQL for the database on the IOT side.

Keywords:

Quick Response (QR) Code, IOT, Power control, NodeMCU

INTRODUCTION

Life without electricity can never be imagined in this world, so it's every human duty to save electricity. But due to the busy schedule existing in present, often many of us forget to switch off lights and fans which increase wastage of electricity. Often we find lights and fans in the classroom will be on though the classroom is empty which increases the electricity bill. This is the major issue in most of the educational institutions. Over the past decade, there has been significant advancement and innovations in the field of consumer electronics by using new technologies we can automate the control of main power supply provided to the classroom which significantly reduces the power consumption. Automation provides some sort of automatic control to the electrical appliances present in the building. (ICRAECT)

The project that the researchers created allows users to manage and keep an eye on the room's power supply. A power source's status at any institution, including whether it is on or off, can be seen by the operator using the website on the laptop, computer, or CP and NodeMCU. And the operator may just click a button on the website control panel on the laptop, computer, or CP or flip a physical switch to turn on or off the lighting in the particular location where he likes. This project can reduce effort and conserve energy. For instance, check the website monitor on your laptop/computer/CP to make sure the lights on the second floor are off before you leave the room.

The student won't have to bother about turning on and off the lights when they leave the room as a result. On the other hand, thanks to the monitoring system, we can keep track of the amount of time spent in each area each day and avoid having to determine which room is being used.

To save energy, turn off the electricity when you leave your room. Additionally, it can help reduce emissions of greenhouse gases like carbon dioxide. As a result, shutting off your lights is a simple way to help preserve the environment and the world. In accordance with the basic recommendations, it is imperative that you switch off your lights. If your lights are incandescent, you must turn them off if you plan to be out from your room for more than a minute. By turning off your lights, you may reduce the amount of non-renewable resources that you use and harm the environment.

PURPOSE OF THE STUDY

This study seeks to measure the solar cell efficiency. Specifically, this study shall:

1. To understand the characteristics and functions of a NODEMCU (ESP8266) microcontroller
2. To integrate Quick Response Code as a switching device with monitoring mechanism using Internet of Things (IOT).
3. To design a Lighting and Power Control with Monitoring System using Quick Response (QR) Code with NODEMCU (ESP8266) Micro-controller.

BLOCK DIAGRAM

The easiest way to comprehend a system's operation is to break it down into its component elements and functions in a diagram or set of blocks. The project's whole flow is depicted in the block diagram below. Each component is identified and given a name before a narrative explanation intended for specification follows.

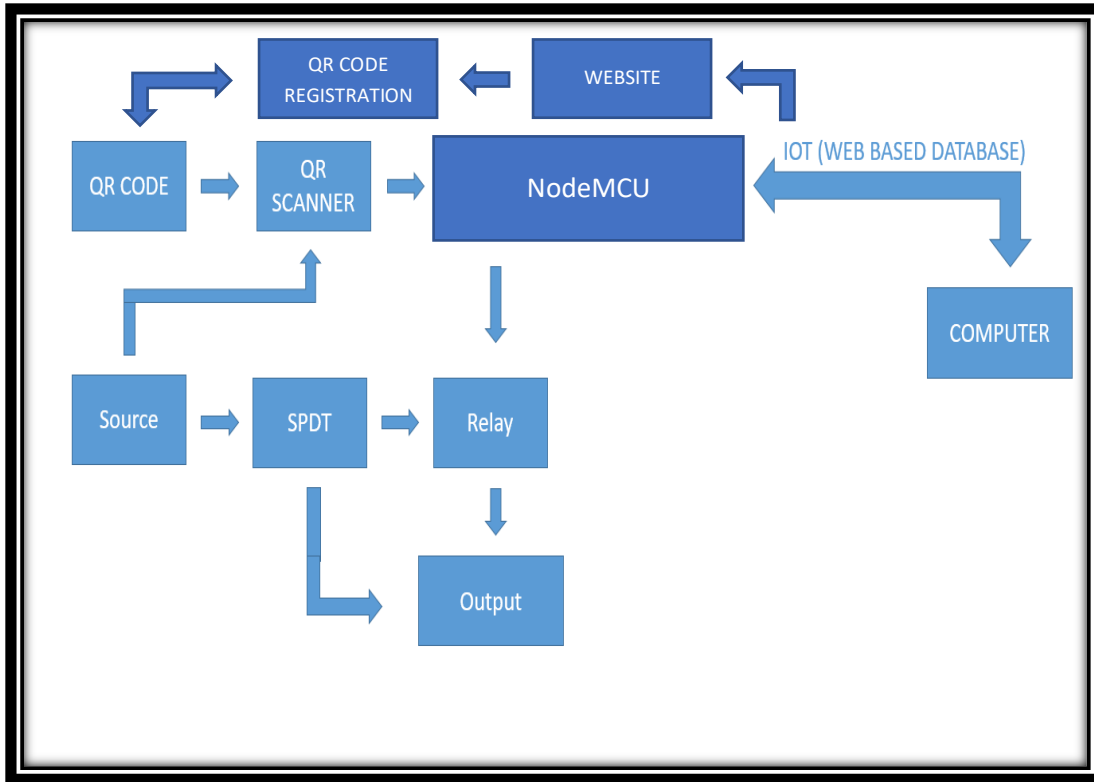

Figure 1: Block Diagram of the System

WORKING PRINCIPLE

Every output in the circuit will be controlled by the NodeMCU, however internet access is required. To regulate the lights and power in a classroom, however, operators must first register on the website that the researchers created. Following registration, the operator will receive a unique QR code that they may use to manage the power source. To check if the QR code that was scanned is registered, the QR scanner that is supplied by DC source will scan the code, send it to the microcontroller (NodeMCU), and then transfer it to the website's database. The Nodemcu will alter the relay that controls that AC power source in accordance with the operator's wishes if the scanned QR code is registered. There is also a page in the website for removing QR codes if necessary.

When the QR code is successfully scanned, there is an "attendance" page on the monitoring side where you can get a list of the operators who scanned their QR codes along with the date, time, and classroom they were in.

The researchers created a float switch on the website for manual operations when the system malfunctions, allowing the administrator to change the classroom's power source. Alternatively, a double throw switch that was attached allows you to manually alter the manner using standard operation when there is no internet.

SCOPE OF THE STUDY

There are several factors to consider because this project is a modified design of automated power control. We will talk about the project's scope and restrictions, as well as what to do and what not to do. This presentation will also explain the fields that should and should not be affected. The follow are the scope and limitation of the designed project:

1. The designed project does not work when there is no internet access.
2. Programming language is used to manage the concept of the design.
3. The design uses NodeMCU as this component is programmable.
4. Only clear QR codes will be read by the scanner.

DEFINITION OF TERMS

This section of the paper defines any concepts that could be difficult for readers who are unfamiliar with or just have a passing familiarity with the subject matter of the project to understand.

The definition will follow the use and language found in the actual publication. The definitions that follow are as follows:

1. Quick Response (QR) Code Scanner

- is an optical scanning device that's able to read QR codes. Most tablets and smartphones have built-in QR code scanners in their cameras. That means you can likely point your camera at a QR code and be able to scan and read it.

2. NodeMCU

- is an open source platform based on ESP8266 which can connect objects and let data transfer using the Wi-Fi protocol. Overview. NodeMCU is an open source firmware for which open source prototyping board designs are available. The name "NodeMCU" combines "node" and "MCU" (micro-controller unit). Strictly speaking, the term "NodeMCU" refers to the firmware rather than the associated development kits.

3. Relay

- is an electrically operated switch. It consists of a set of input terminals for a single or multiple control signals, and a set of operating contact terminals. The switch may have any number of contacts in multiple contact forms, such as make contacts, break contacts, or combinations thereof.

4. DC Power

- Any source of electrical power intended only for DC devices/machines.

5. AC Power

- Any source of electrical power intended.

6. Single Pole Double Throw Switch

- Which is used to control two dissimilar circuits through a similar single input. The operating of this switch can be done manually or included through the electromagnetic coil.

7. Switch

- In an electric circuit is to either make or break the electric circuit. A switch is used to turn current to an electrical appliance either on or off. It is used in the designed project to control the bulb that represents the load classroom.

8. Receptacle

- An electrical outlet into which the plug of an electrical device may be inserted. It is used in the designed project as the load of the classroom.

9. Bulb

- A light-bulb produces light from electricity. In addition to lighting a dark space, they can be used to show an electronic device is on, to direct traffic, for heat, and for many other purposes. . It is used in the designed project as the load of the classroom.

METHODOLOGY

A particular kind of design process that incorporates techniques for gathering and analyzing data that are crucial to the project's development. The system flow chart, which comprises the project's logic, the wiring schematic, and the software to be uploaded to the programmable microprocessor are all included. The flowchart displays each step that went into creating the project, as seen in figure 2.

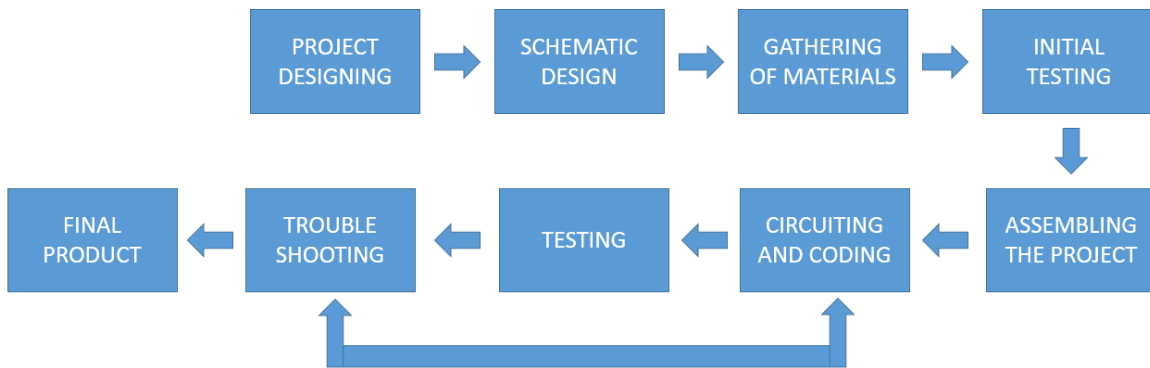

Figure 2: Project plan process flow

DESIGNING THE PROTOTYPE

The first step includes designing of the prototype. The planning of the design was carried using AutoCAD. The designed prototype was open for changes, it is shown in figure 3.

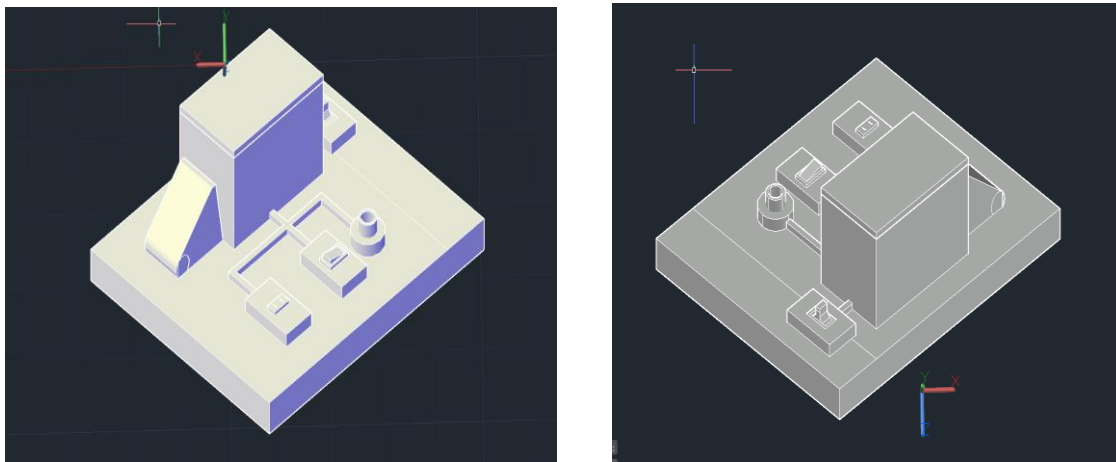

Figure 3: Designing of the prototype

SCHEMATIC DESIGN

Using proteus, a schematic design was made for the project. To determine of the designed project is viable or not. The schematic circuit is given below:

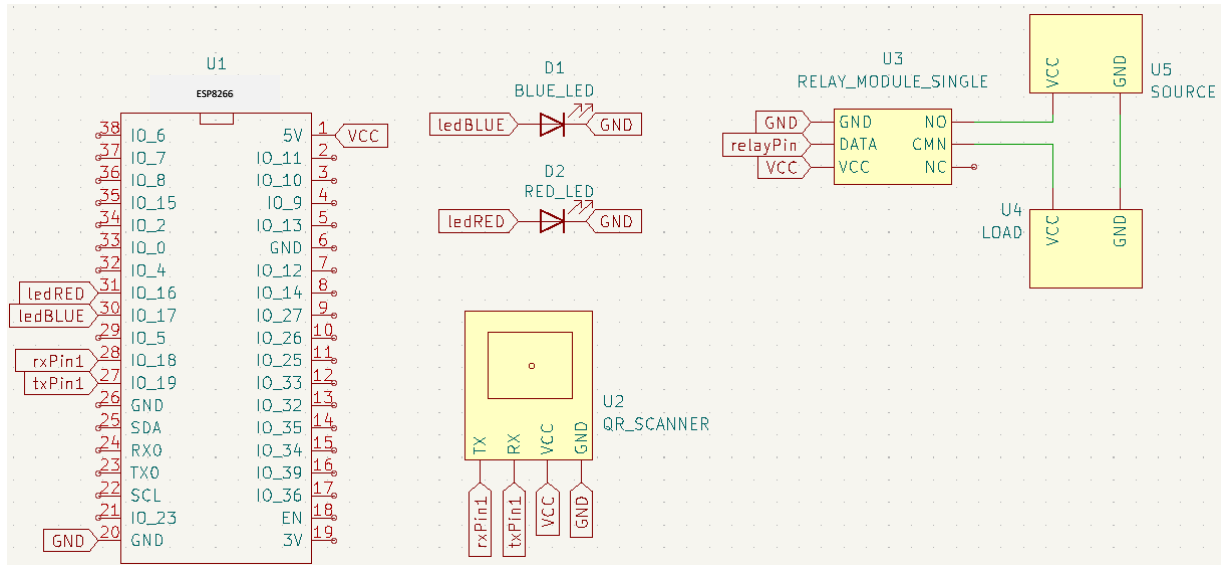

Figure 4: Schematic Diagram

DC power source is connected to the NodeMCU, QR scanner relay for it to function. Then transmitter and receiver pin are connected to pin27 and pin28 of the NodeMCU where it goes to the transmitter and receiver of the QR scanner. An additional LED (Blue and Red) is connected to pin30 and pin31 as an indicator. While the relay is connected to the power source that is to be controlled as shown in figure 4.

GATHERING OF MATERIALS

The gathering of materials are made through online. The researchers used an online platform to order that materials that is needed to complete the designed project.

INITIAL TESTING

After the materials arrived. The researchers initially tested the materials if it is compatible with the NodeMCU microcontroller.

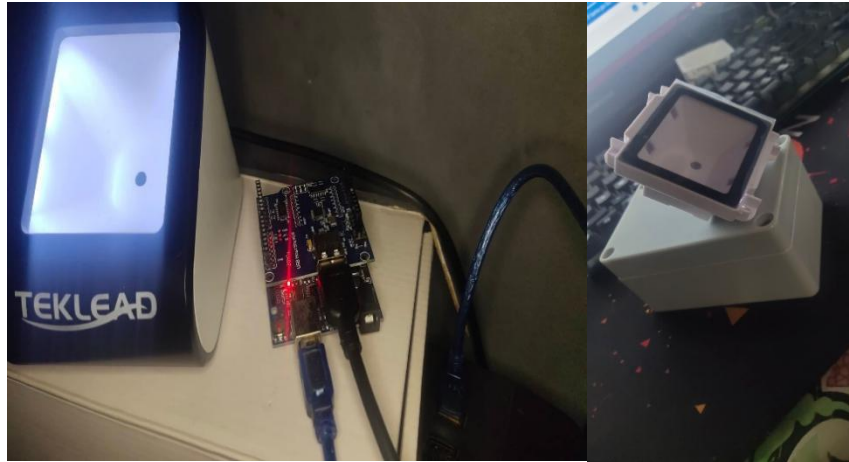

Figure 5: Testing of materials

The researchers chose to purchase a new QR scanner because the original one they purchased didn't function with the NodeMCU.

ASSEMBLING THE PROJECT

The project's assembly is the next phase. This involves creating the project's case, mounting the load on the platform, and getting the cables ready for connection to the intended prototype.

CIRCUITING AND CODING

Circuiting and coding involves connecting the actual wires of the designed project and uploading the program codes to the microcontroller.



Figure 6. Actual design of the prototype

Figure 6 is an actual image of the intended project; the prototype's wiring using the designed schematic diagram and programming have already been completed.

NODEMCU CODING:

```
#include "ArduinoJson.h"
```

```
#include <EEPROM.h>
```

```
#include <WiFi.h>
```

```
#include <WiFiMulti.h>
```

```
#include <HTTPClient.h>
```

```
#include <PubSubClient.h>
```

```
#include <WiFiClient.h>
```

```
WiFiMulti wifiMulti;
```

```
//MQTT Parameters
```

```
const char* mqttServer = "driver.cloudmqtt.com";
```

```
const int  mqttPort   = 18933;
```

```
const char* mqttUser   = "gnigrukf";
```

```
const char* mqttPassword = "4YkZBFFRAgIy";
```

```
WiFiClient  espClient;
```

```
PubSubClient client(espClient);
```

```
//ESP POST
```

```
int counter = 1;
```

```
const char* ssid = "HUAWEI(MAX 7 USER)";
```

```
const char* password = "Scan QR Code";
```

```
String QRserver =
```

```
"http://mactechph.com/operatormanagement/QR%20Checking/checkOperatorQR.php?oprID=SB  
C853";
```

```
String QRweb =
```

```
"http://mactechph.com/operatormanagement/QR%20Checking/checkOperatorQR.php?oprID=";
```

```
//CONNECTION
```

```
int httpCode;
```

```
int compileData[] = {};
```

```
int ndex = 0;
```

```
String parse[] = {"A", "B", "A", "B", "A", "B", "A", "B"};
```

```
String parser;
```

```
String QRcode;
```

```
int placement = 0;
```

```
struct State {
```

```
int decoding = 0;
```

```
int clearVar = 0;

int converting = 0;

bool relay = 1;

};

State state;

//JSON

struct Data {

    String json;

};

Data data;

String ref[][2] = {

    {"A", "95"},

    {"B", ""}, //175 30

    {"C", "94"},

    {"D", ""}, //87 30

    {"E", "93"},

    {"F", ""}, //174 30

    {"G", "92"},
```

{"H", ""}, //171 30

{"I", "91"},

{"J", ""}, //173 30

{"K", "90"},

{"L", ""}, //86 30

{"M", "89"},

{"N", ""}, //172 30

{"O", "88"},

{"P", ""}, //85 0

{"Q", "87"},

{"R", ""}, //171 0

{"S", "86"},

{"T", ""}, //85 30

{"U", "85"},

{"V", ""}, //170 30

{"W", "84"},

{"X", ""}, //170 0

{"Y", "83"},

```
 {"Z", ""},//169 30

 {"0", ""},//

 {"1", "103"},

 {"2", ""},//179 30

 {"3", "102"},

 {"4", ""},//89 30

 {"5", "101"},

 {"6", ""},//178 30

 {"7", "100"},

 {"8", ""},//172 0

 {"9", "99"},

};

int checker = 1;

String decoded;

int endCheck;

#define ledBLUE 17

#define ledRED 16

#define relayPin 32
```

```
void setup()

{

  Serial.begin(115200);

  Serial.println("START");

  pinMode(ledRED, OUTPUT);

  pinMode(ledBLUE, OUTPUT);

  pinMode (relayPin, OUTPUT);

  digitalWrite(ledBLUE, HIGH);

  digitalWrite(ledRED, HIGH);

  digitalWrite(relayPin, HIGH);

  // Init MQTT

  client.setServer(mqttServer, mqttPort);

  client.setCallback(callback);

  // WIFI SETUP

  WiFi.begin(ssid, password);

  Serial.println("Connecting");

  while (WiFi.status() != WL_CONNECTED) {

    Serial.print(". ");
```

```
    delay(150);

}

if (WiFi.status() == WL_CONNECTED) {

    connectToMQTT();

}

digitalWrite(ledBLUE, LOW);

digitalWrite(ledRED, LOW);

state.decoding = 0;

}

void loop()

{

    client.loop();

    checkMQTTConnectivity();

    if (state.decoding == 0) {           // Clear Serial Buffer.

        Serial.println("reset");

        decoded = "";

        state.decoding = 1;

    }

}
```

```

if (mySerial.available())           // Check if there is Incoming Data in the Serial Buffer.

{   while (mySerial.available())     // Keep reading Byte by Byte from the Buffer till
the Buffer is empty

{

    decoded = decoded + String(mySerial.read()) + "*";

    state.decoding = 2;

}

}

if (state.decoding == 2) {          // Check Serial Data.

    if (state.clearVar == 0) {

        state.decoding = 0;

        state.clearVar = 1;

    }

    unsigned int indexStarter = 0;

    unsigned int indexEnder = 0;

    int remover;

    indexEnder = decoded.indexOf("*121*");

    remover = indexEnder;

    if (indexEnder > 0 && indexEnder < 1000 ) {

```

```

int sized = decoded.length();

decoded.remove(sized - 4, 4);

state.decoding = 3;

}

indexStarter = decoded.indexOf("0*");

remover = indexStarter;

if (indexStarter >= 0 && indexStarter < 1) {

    decoded.remove(remover, 2);

    state.decoding = 0;

}

}

if (state.decoding == 3) {           // Process Serial Data.

    parseData(decoded);

    converter();

    sendQR();

    validationQR();

    state.decoding = 0;

} }

```

WEBSITE CODING:

```
<?php

    // // session_destroy();

    session_start();

    session_unset();

    unset($_SESSION['filemanagement']);

?>

<!DOCTYPE html>

<html lang="en-us">

    <head>

        <meta name="viewport" content="width=device-width, initial-scale=1.0">

        <title>Operator Management</title>

        <!-- Customized CSS -->

        <link rel="stylesheet" type="text/css" href="resources/css/style.css?random=<?= uniqid()

?>">

        <link rel="preconnect" href="https://fonts.googleapis.com">

        <link rel="preconnect" href="https://fonts.gstatic.com" crossorigin>
```

```
<link
href="https://fonts.googleapis.com/css2?family=Montserrat:wght@200;300;400;500;600;700&d
isplay=swap" rel="stylesheet">
```

```
<!-- ION ICONS -->
```

```
<script type="module"
src="https://unpkg.com/ionicons@5.5.2/dist/ionicons/ionicons.esm.js"></script>
```

```
<script nomodule=""
src="https://unpkg.com/ionicons@5.0.0/dist/ionicons/ionicons.js"></script>
```

```
</head>
```

```
<body class = "login-page-design">
```

```
<div class="container">
```

```
<div class="login-form">
```

```
<form class= "login-form-container" method = "post"
action="resources/data/log.php">
```

```
<h2 class = "title-text">OPERATOR MANAGEMENT</h2>
```

```
<div class="form-content">
```

```
<input class = "form-content-textbox" type="text" name="username" value=""
placeholder="Username" required>
```

```
</div>
```

```
<div class="form-content">
```

```
        <input class = "form-content-textbox" type="password" name="password"
value="" placeholder="Password" required>

    </div>

    <div class="row">

        <input type="submit" value="LOGIN">

    </div>

</form>

</div>

</div>

</body>

</html>
```

TESTING AND TROUBLESHOOTING

The researchers finished the prototype and started the test runs and troubleshooting. This process is important because the purpose of this is to know if the project will work by determining the result of the prototype when it is functioning properly. The researchers did the final test runs and troubleshooted the project to see if there were no errors and if the project would function properly. Fortunately, the QR code scanner did work properly and is ready to be used. They then fixed the monitoring system by reviewing the code of the QR code scanner and the version of the application. Also, they painted the QR code scanner and put some indicator for the Wi-Fi connection and for the register QR code is Green and not registered QR code is red the indicators.

FINAL PRODUCT

For the last shape of the procedure that we made the finalization of our product.

This includes the finalization of the prototype, all the materials are attached in black painted plywood and we added the double throw switch as a final piece of the prototype, for the wiring we used moulding for presentable output. Finally, the design project made by the researchers was completed.



Figure 7: Final product of the project

RESULTS AND DISCUSSIONS

The researchers made the prototype & test and run the project based on our plan. A prototype was created for the project presentation.

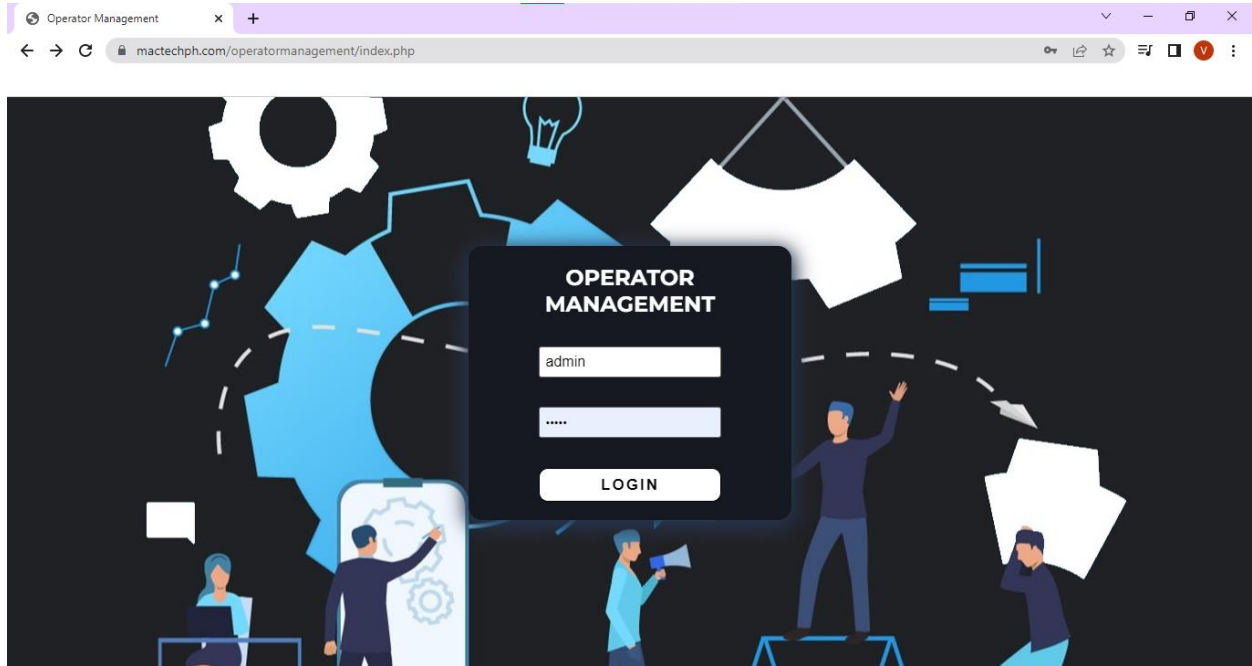

Figure 8: Website page for the administrator

The user can input commands via the website Application Control Display switch or manual switch mode in this project, which is based on the website and NodeMCU. The software analyzes the data before sending it to the NodeMCU. As a server, the NodeMCU analyzes the data and turns on the relay switch, which turns on the room's power supply. In this project, a three-way switch was added to the setup, and a straightforward automation procedure was completed. This prototype effectively controls and monitors any establishment's or room's electricity system using a CP, laptop, or computer.

The team developed software for the website that allows the NodeMCU to transmit and receive data using a QR code scanner to manage and monitor the power source. This project

is operated by clicking the program with the toggle power that corresponds to each room that is connected to the relay on a computer, laptop, or CP. The signal is then sent to NodeMCU via serial communication so that it may manage and keep an eye on the power source.

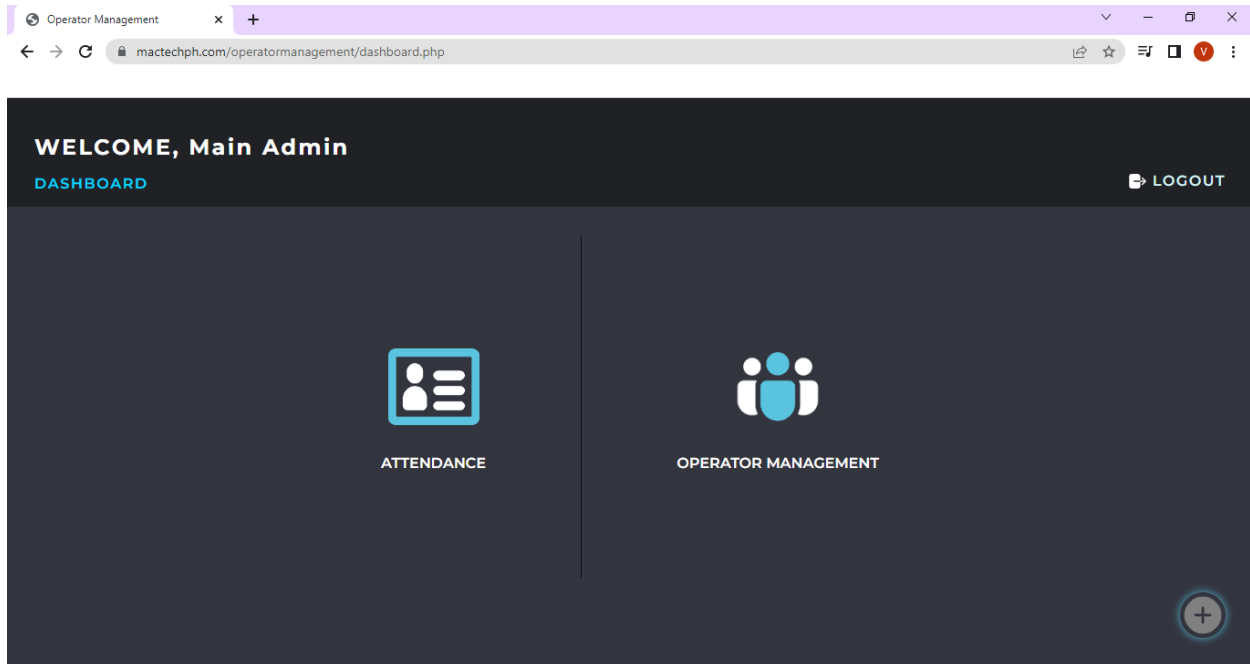

Figure 9: Website dashboard for the administrator

Only controlling and keeping an eye on the room's power supply is the main objective of this project. The researchers tested a prototype in a light bulb and an electrical outlet. And because they only run their tests on one power source, the researchers only concentrate on that one. In order to have a controlling and monitoring system in the laptop/computer or CP utilizing the website, the researchers first employed the website. The monitoring display allows us to examine the room's usage status as well as the operator, time, and date of each operation.

By integrating this system, automation control of the power source using the QR code, monitoring the utilization of the power source through website, and limiting the authorized personnel that can use the power source can be obtain.

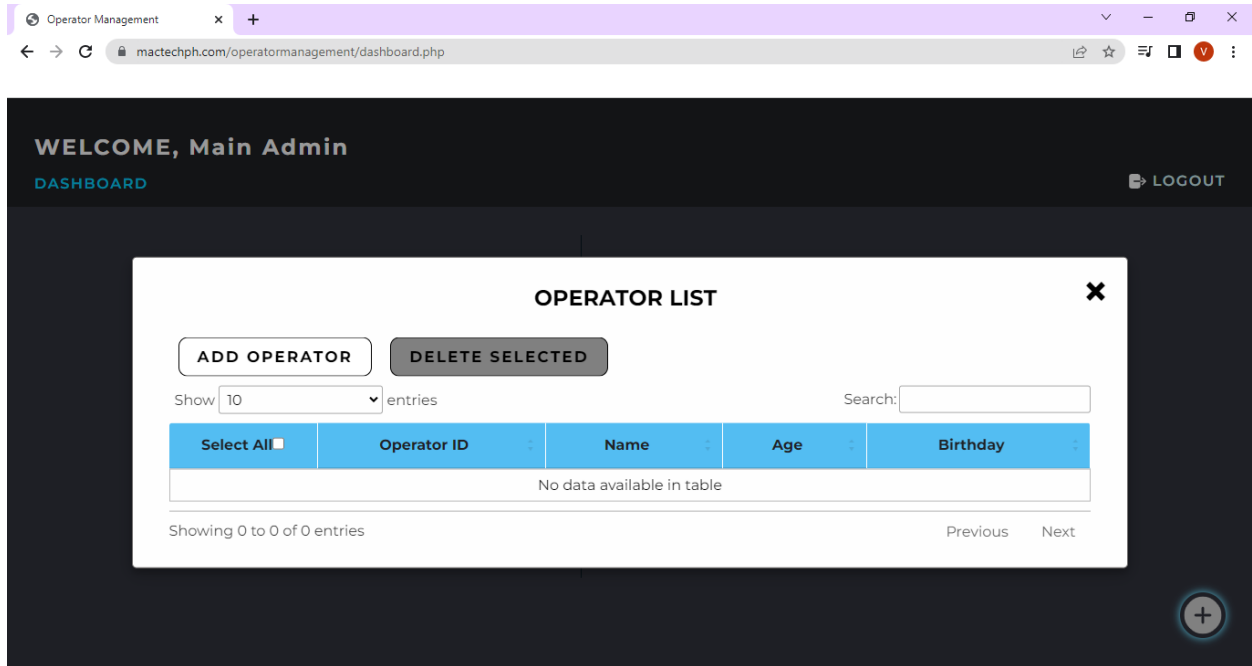

Figure 10: Registration and Deletion of Operator

Figure 10 shows where to register or delete the operator's ID or QR code. Registration information like name, age and birthday of the operator needs to be filled. When an operator needs to be removed of a certain QR code needs to be delete, the administrator can just simply select the row that needs to be deleted then just click delete.

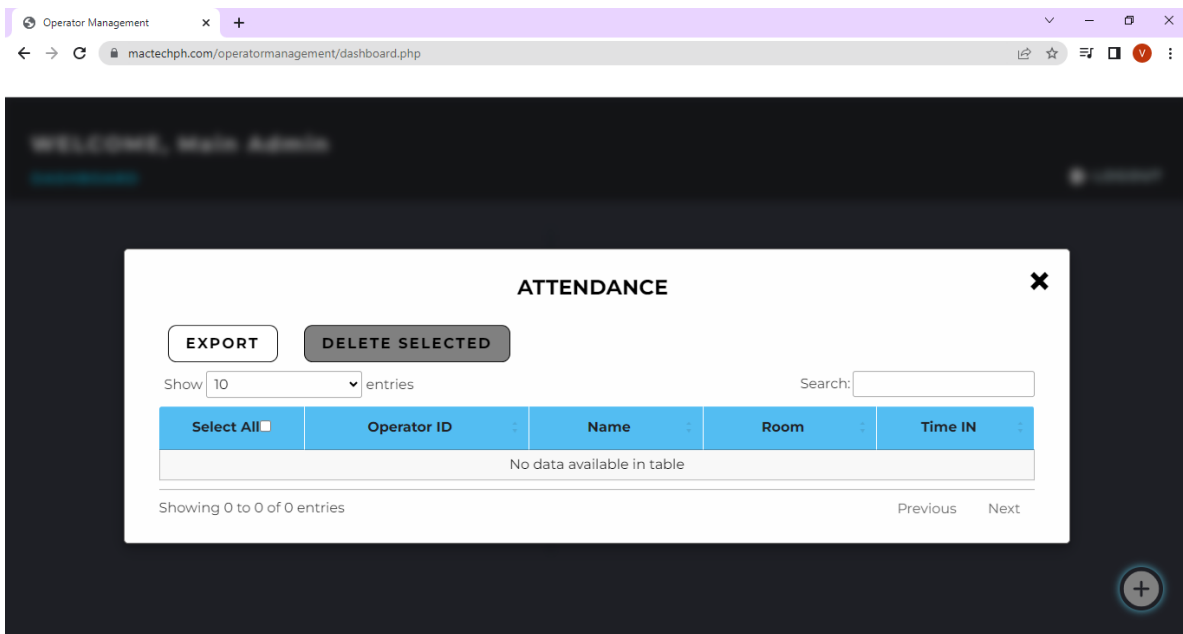

Figure 11: Monitoring logs of the project.

Figure 11 shows the monitoring side of the project, where the administrator can check who scanned their QR code, classroom did they used and the time and date.

CONCLUSION

Automation of power control can be done in a variety of ways. This project attains futuristic automation with the addition of monitoring system. By this project, energy conservation will be more efficient and easy. With the addition of its functions, classrooms and schools can maximize the efficiency of their use of electricity.

RECOMMENDATIONS

The researchers anticipate future generations to pay attention to this field of knowledge since it is an interesting topic that is contemporary and important for the country. The following suggestions are made based on the findings of the study:

- 1.) When more research is done, this system can be used without using the internet by using local database and local hosting of the website.
- 2.) Due to budgetary constraints, the researchers seek to improve the development further by adding more QR scanner as the representation of every school/classroom, but they are unable to do so due to market pricing and the shortage of unique materials that must be employed.
- 3.) Future researcher can use other microcontroller raspberry pi to improve the function more specifically with the connection with the website.

4.) This study can be broaden not just for the classrooms or school but for homes, companies and other sectors in the community.

LITERATURE CITED

How to Program NodeMCU on Arduino IDE, by osoyooproduct in Circuits

Retrieved January 2023, from <https://www.instructables.com/How-to-ProgramNodeMCU-on-Arduino-IDE/>

What Is a QR Code? QR Code Meaning & Example, by Scott Schulfer

Retrieved January 2023, from <https://www.sproutqr.com/blog/what-is-a-qr-code>

NodeMCU, by Wikipedia

Retrieved January 2023, from <https://en.wikipedia.org/wiki/NodeMCU>

What Is A Relay?, by Rick Grigalunas

Retrieved January 2023, from <https://www.escomponents.com/blog/2019/7/31/what-is-a-relay>

What is SPDT Switch : Working & Its Applications, by elprocus

Retrieved January 2023, from <https://www.elprocus.com/spdt-switch/>

What is an electrical Switch?, by Omron

Retrieved January 2023, from <https://components.omron.com/us-en/products/basicknowledge/switches/basics>

Electrical Outlet, by Energy Education

Retrieved January 2023, from

https://energyeducation.ca/encyclopedia/Electrical_outlet

Light Bulb, by Wikipedia

Retrieved January 2023, from https://simple.wikipedia.org/wiki/Light_bulb

Light Bulb Socket, by Wikipedia

Retrieved January 2023, from

[https://en.wikipedia.org/wiki/Lightbulb_socket#:~:text=A%20lightbulb%20socket%20C%20light%20bulb%20holder,replaced%20\(re%2Dlamping\).](https://en.wikipedia.org/wiki/Lightbulb_socket#:~:text=A%20lightbulb%20socket%20C%20light%20bulb%20holder,replaced%20(re%2Dlamping).)

APPENDICES

APPENDIX A - GANTT CHART

APPENDIX B- DEVICES AND WEBSITE

APPENDIX C- NODEMCU CODE

APPENDIX D- DESIGN AND TESTING

APPENDIX A

Faith Garcia								
Vit McDowell Sarigumba								
Jude Andrew Tagaan								
		SEPTEMBER			OCTOBER			
1. PROPOSAL OF RESEARCH								
2. PROJECT DESIGNING								
3. SCHEMATIC DESIGN								
4. GATHERING OF MATERIALS								
		NOVEMBER			DECEMBER			
5. INITIAL TESTING								
6. ASSEMBLING THE PROJECT								
7. CIRCUITING AND CODING								
8. TESTING & TROUBLE-SHOOTING								
9. INITIAL CHECKING								
10. FINAL CHECKING								
		JANUARY						
11. MOCK DEFENSE								
12. FINAL DEFENSE								

Gantt Chart

APPENDIX B



Material used to complete the project.

APPENDIX C

NODEMCU CODES

```
#include "ArduinoJson.h"

#include <EEPROM.h>

#include <WiFi.h>

#include <WiFiMulti.h>

#include <HTTPClient.h>

#include <PubSubClient.h>

#include <WiFiClient.h>

WiFiMulti wifiMulti;

//MQTT Parameters const char* mqttServer =

"driver.cloudmqtt.com"; const int  mqttPort

= 18933; const char* mqttUser =

"gnigrukf"; const char* mqttPassword =

"4YkZBFFRAGIy"; WiFiClient

espClient;
```

```
PubSubClient client(espClient);

//ESP POST

int counter = 1; const char* ssid =

"HUAWEI(MAX 7 USER)"; const char*

password = "Scan QR Code";

String QRserver =

"http://mactechph.com/operatormanagement/QR%20Checking/checkOperatorQR.php?oprID=

S BC853";

String QRweb =

"http://mactechph.com/operatormanagement/QR%20Checking/checkOperatorQR.php?oprID=

";

//CONNECTION

int httpCode;

int compileData[] = {};

int ndex = 0;

String parse[] = {"A", "B", "A", "B", "A", "B", "A", "B"};

String parser;
```

String

QRcode; int

placement =

0;

struct State {

int decoding =

0; int

clearVar = 0;

int converting

= 0; bool

relay = 1; };

State state;

//JSON

struct

Data {

```
String json;

};

Data data;

String ref[][2] = {

    {"A", "95"},

    {"B", ""}, //175 30

    {"C", "94"},

    {"D", ""}, //87 30

    {"E", "93"},

    {"F", ""}, //174 30

    {"G", "92"},

    {"H", ""}, //171 30

    {"I", "91"},

    {"J", ""}, //173 30

    {"K", "90"},

    {"L", ""}, //86 30
```

{"M", "89"},
{"N", ""},//172 30 {"O", "88"},
{"P", ""},//85 0
{"Q", "87"},
{"R", ""},//171 0
{"S", "86"},
{"T", ""},//85 30
{"U", "85"},
{"V", ""},//170 30
{"W", "84"},
{"X", ""},//170 0
{"Y", "83"},
{"Z", ""},//169 30

{"0", ""},//
{"1", "103"},
{"2", ""},//179 30
{"3", "102"},

```
{"4", ""}, //89 30 {"5", "101"},
```

```
{"6", ""}, //178 30
```

```
{"7", "100"},
```

```
{"8", ""}, //172 0
```

```
{"9", "99"},
```

```
};
```

```
int checker
```

```
= 1; String
```

```
decoded;
```

```
int
```

```
endCheck;
```

```
#define ledBLUE 17
```

```
#define ledRED 16
```

```
#define relayPin 32
```

```

void setup()
{

  Serial.begin(115200);

  Serial.println("START");

  pinMode(ledRED, OUTPUT);

  pinMode(ledBLUE, OUTPUT);

  pinMode (relayPin, OUTPUT);

  digitalWrite(ledBLUE, HIGH);

  digitalWrite(ledRED, HIGH);

  digitalWrite(relayPin, HIGH);

//          Init          MQTT

client.setServer(mqttServer,
mqttPort);

client.setCallback(callback);

// WIFI SETUP

WiFi.begin(ssid, password);

```

```
Serial.println("Connecting");
while (WiFi.status() != WL_CONNECTED) {

    Serial.print(". ");

    delay(150);

}

if (WiFi.status() == WL_CONNECTED) {

connectToMQTT();

}

digitalWrite(ledBLUE,
LOW);
digitalWrite(ledRED,
LOW); state.decoding = 0;

}

void loop()

{
```

```

client.loop();
checkMQTTConnectivity();

if (state.decoding == 0) {           // Clear Serial

Buffer.  Serial.println("reset");  decoded = "";

state.decoding = 1;

}

if (mySerial.available())           // Check if there is Incoming Data in the Serial

Buffer.  {

    while (mySerial.available())     // Keep reading Byte by Byte from the Buffer till the
Buffer is empty

    {

        decoded = decoded + String(mySerial.read()) + "*";

state.decoding = 2;

}

```

```
}
```

```
if (state.decoding == 2) {           // Check Serial Data.
```

```
    if (state.clearVar == 0) {
```

```
state.decoding = 0;
```

```
state.clearVar = 1;
```

```
    }
```

```
    unsigned int indexStarter =
```

```
0;    unsigned int indexEnder
```

```
= 0;    int remover;
```

```
    indexEnder =
```

```
decoded.indexOf("*121*");    remover =
```

```
indexEnder;    if (indexEnder > 0 &&
```

```

indexEnder < 1000 ) {    int sized =

decoded.length();    decoded.remove(sized

- 4, 4);

    state.decoding = 3;

}

    indexStarter = decoded.indexOf("0*");

remover = indexStarter;    if (indexStarter

>= 0 && indexStarter < 1) {

decoded.remove(remover, 2);

state.decoding = 0;

} } if (state.decoding == 3) {    // Process

```

Serial Data.

```

parseData(decoded)

;    converter();

sendQR();

```

```

validationQR());

state.decoding = 0;

}

}

void getDatatoWeb() { //CHECK WIFI CONNECTION AND AVAILABILITY OF
DATA

// wait for WiFi connection if
(WiFi.status() == WL_CONNECTED)

{ HTTPClient http;

http.begin(QRserver.c_str()); //HTTP

// start connection and send HTTP header

httpCode = http.GET();

// httpCode will be negative on
error if (httpCode > 0) {

// HTTP header has been send and Server response header has been handled

```

```

Serial.printf("[HTTP] GET... code: %d\n", httpCode);

// file found at server

if (httpCode == HTTP_CODE_OK) {

    data.json = http.getString();

    Serial.println(data.json);

}

} else {

    Serial.printf("[HTTP] GET... failed, error: %s\n", http.errorToString(httpCode).c_str());

//Connected to Wifi but do data received

    Serial.println("Connected but no Data");

}

http.end()

;

} else {

    Serial.println("connectWIFI Failed, ReconnectWIFI Again");    //Not Connected to Wifi

} } void

sendQR() {

```

```

QRserver = QRweb + String(QRcode);

getDatatoWeb();

}

void validationQR() { unsigned int

indexFinder1 = 0; unsigned int indexFinder2

= 0; indexFinder1 =

data.json.indexOf("Successfully");

indexFinder2 = data.json.indexOf(" does not

exist");

if (indexFinder1 < 1000) {

Serial.println("Relay

Trigger");

digitalWrite(ledBLUE,

HIGH);

state.relay = !state.relay;

digitalWrite(relayPin,

```

```
state.relay);  delay(500);

digitalWrite(ledBLUE, LOW);

}

if (indexFinder2 < 1000) {

Serial.println("Error");

digitalWrite(ledRED, HIGH);

delay(500);

digitalWrite(ledRED, LOW);

}

}
```

APPENDIX D

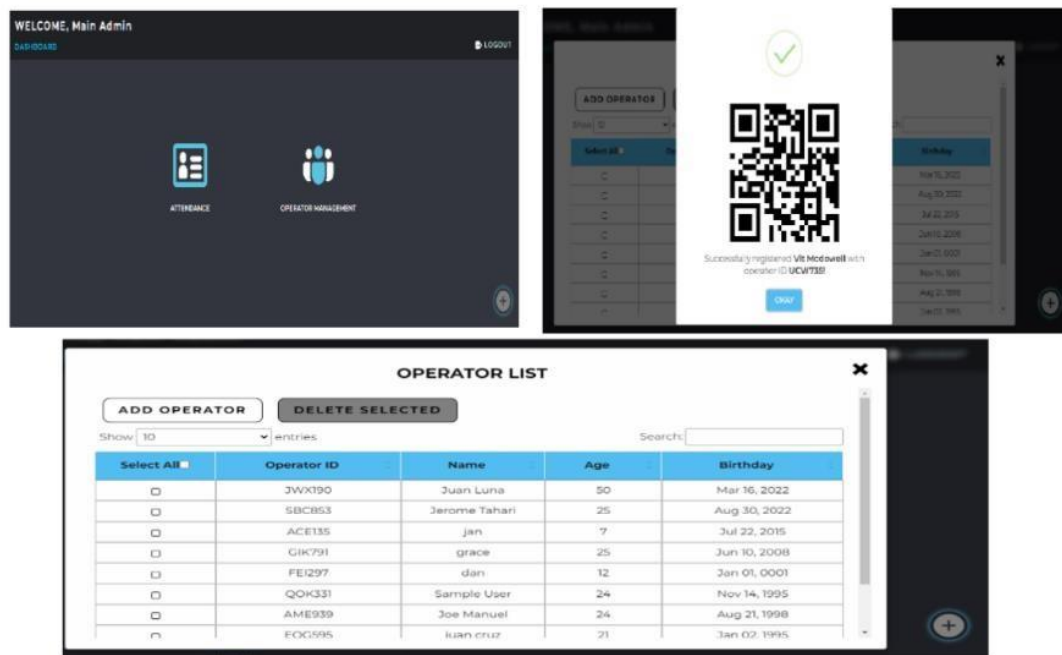

Designing the website system of the designed project

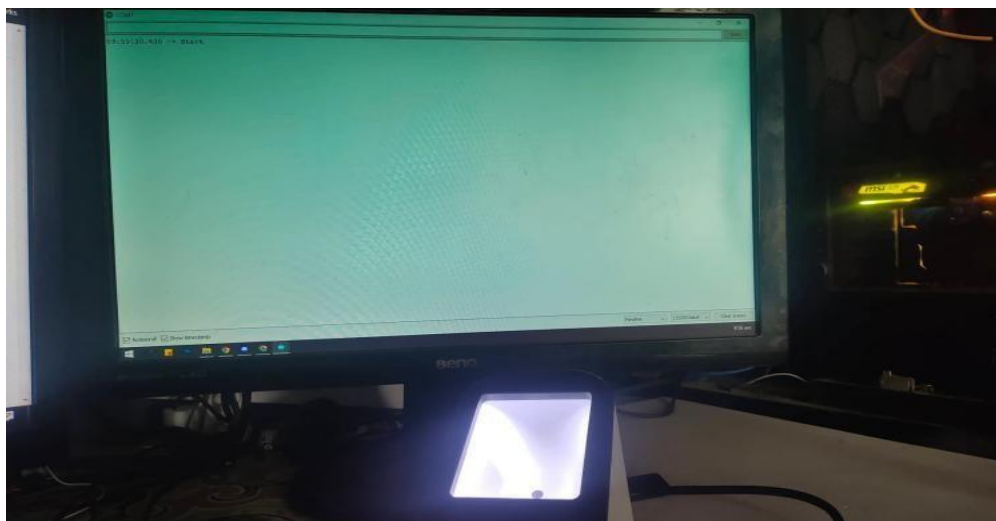

Coding of QR code scanner and communicating of the website



Connecting our circuit project in relay to NodeMCU to the QR code

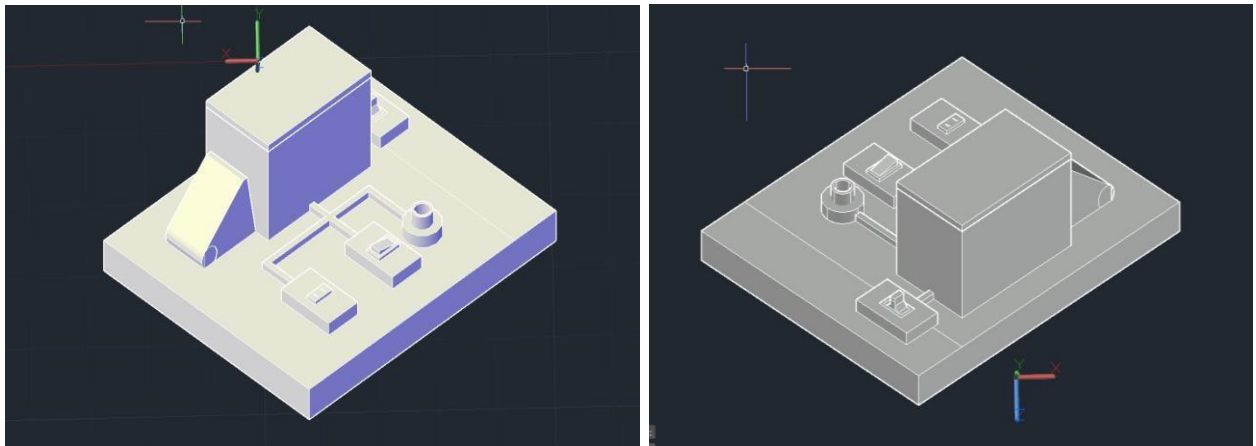

Proposed design for the prototype



The prototype load power source on using manual application



The prototype load power source off using manual application



The prototype load power source on using website application



The prototype load power source off using website application.

A. Personal Data

Name: Faith R. Garcia

Sex: Male

Date of Birth: July 25, 1999

Age: 23

Place of Birth: Kolambugan Lanao del Norte

Citizenship: Filipino

Father: Lupito R. Garcia

Mother: Delia R. Garcia

Residence: P-2 Balagatasa Maigo Lanao del Norte

Civil Status: Single

Religion: IFI

Motto in life: "If you don't take risks, you can't create a future."

Email Address: faith.garcia360@gmail.com



B. Educational Attainment

Elementary: Maigo Elementary School

High school: Maigo National High School

Track: Academic

1st Course: Diploma in electrical engineering technology 2 years course

College: Misamis University

Course: Bachelor of Science in Electrical Engineering

A. Personal Data

Name: Vit Mcdowell P. Sarigumba

Sex: Male

Date of Birth: December 03, 1998

Age: 24

Place of Birth: MOPH

Citizenship: Filipino

Father: Vito R. Sarigumba

Mather: Mildred P. Sarigumba

Residence: Lobogon, Aloran, Misamis Occidental

Civil Status: Single

Religion: Roman Catholic

Motto in life: “It does not matter how slowly you go as long as long as you do not stop.”

Email Address: vitmcdowellsarigumba@gmail.com



B. Educational Attainment

Elementary: Aloran Central Elementary School

High School: Saint Matthews High School

College: Misamis University

Course: Bachelor of Science in Electrical Engineering

